



MOBI**STACK** SMARTO

STORE • MOVE • MANAGE

# MOBISTACK SMARTO

## AN INNOVATIVE AND SMART SPACE SAVING STORAGE SYSTEM



One touch operation

Aisles with access control



### ADVANTAGES



Automated by PLC

Inbuilt safety features



### APPLICATIONS



Maintenance/  
Engineering



Raw Materials



Pharma & Labs



Bulk Records



Spare Parts



Finished Goods



#### Lifecycle

25000 cycles ≡

10 years of operation

#### Lead/lag for LD-7

Approx. 10 mm for  
every 5000 cycles

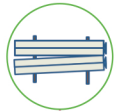

### RELIABILITY



#### Noise level

< 70 Db (industrial norm)

#### Serviceability

25000 cycles ≡

10 years of operation



# FUNCTIONAL FEATURES



Restricted aisle access



Automatic aisle lighting\*



Emergency mode for maintenance activities, breakdowns, etc.



SKU based aisle opening



Audit trail- log in/log out details



Earthquake sensor\*



Ventilation mode for better aeration



Packing function ensures security of the SKUs



In-built safety sensor



Emergency stop button



Safety bumper for pickers' safety



Smooth start-jolt free operations

# SAFETY

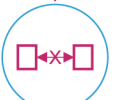

Stop sensors- collision free module movements



Interlocking of aisles with one open aisle



Buzzer based alert system



In-built ELCB

\* Optional

# TECHNICAL FEATURES

System Height H (mm)  
2276,2376,2576,2776,  
2876,3176,3276 & 3476

System Depth (mm)  
SF-336,436,536 & 636  
DF-686,868,1068 & 1268

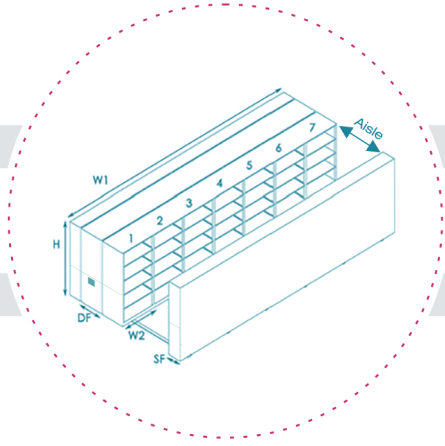

Aisle (mm)  
750-1200

Row Length W1 up to  
7 units (approx 9m)

Shelf Panel (mm)  
Width W2-1300/body  
Depth-300, 400,500& 600

Usable Height (mm)  
2111,2211,2411,2611,  
2711,3011,3111 & 3311

Load Capacity/body  
750 kg/unit



COMPLETE WAREHOUSE STORAGE AND INTRA-LOGISTIC SOLUTIONS

REACH OUT - E : [storage@godrej.com](mailto:storage@godrej.com) T : 1800-419-7060 W : [www.godrejstoragesolutions.com](http://www.godrejstoragesolutions.com)

Godrej Storage Solutions | Godrej & Boyce Mfg. Co. Ltd.  
No.1, SIDCO Industrial Estate, Ambattur, Chennai-600098, Tamil Nadu, India