



MOBISTACK NEO

OPTIMIZE SPACE WITH MAXIMUM FLEXIBILITY!



MAXIMIZING SPACE!

MOBISTACK NEO

- Modern compact shelving system for **space optimization**
- One dynamic aisle at any instant for access, **eliminating unproductive aisles**
- **Quick level adjustability** for changing storage needs
- Modular knockdown design for **future expansion**
- **Japanese technology** for undercarriage and drive units
- **Two tone colour** to enrich the working ambience

FEATURES

- **Modular design** – flexible integration and easily reconfigurable
- Max. load capacity up to **10.5 tons per undercarriage**
- Max. space utilization up to **30ft length**
- Varying height options ranging from **7ft to 11ft**
- **Comprehensive range of design** to store regular, non-regular and bulky SKUs
- **Plethora of accessories** to suit your every need.
- **Reliable** and robust system (tested for 25000+ cycles)



Wheel Assembly

Combination of guided and plain wheel with self aligning plunger block assembly. Smooth and noise-free operations.

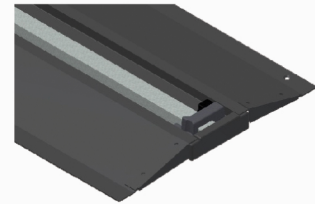

Rails

Rail assembly with slope plate on either side to facilitate safe people movement. Stopper at extreme ends of rails to avoid wheel over run.

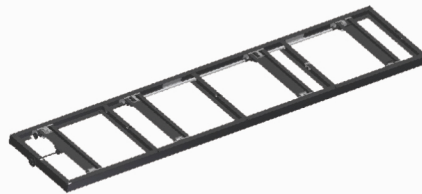

Undercarriage

Sturdy Modular Design, hence flexible to future add-on unlike welded structures. Anti-tipping mechanism to ensure stability while movement.

Drive Unit

Effort reducing design mechanism. Single handle drive for easy & ergonomic operation. Safety knob below handle ensures safe aisle for human access.



Superstructure

Quick level adjustability as no bolted shelves. Wider shelves for more storage space within level. Anti-toppling mechanism for taller units.



MAXIMIZING BUSINESS!

APPLICATIONS



Archive records,
Statutory records,
Centralized bulk documents stores



Spares,
Hardware,
Tools,
Accessories



Pharma Lab Samples
& Equipments,
Medical Supplies



Food & Beverages,
Packing Materials



Apparel,
Garments,
Trims

OPTIONAL ENHANCEMENTS

- Full height divider
- Drawers & pull-out trays
- Doors and wooden floor infill between rails

MOBISTACK NEO

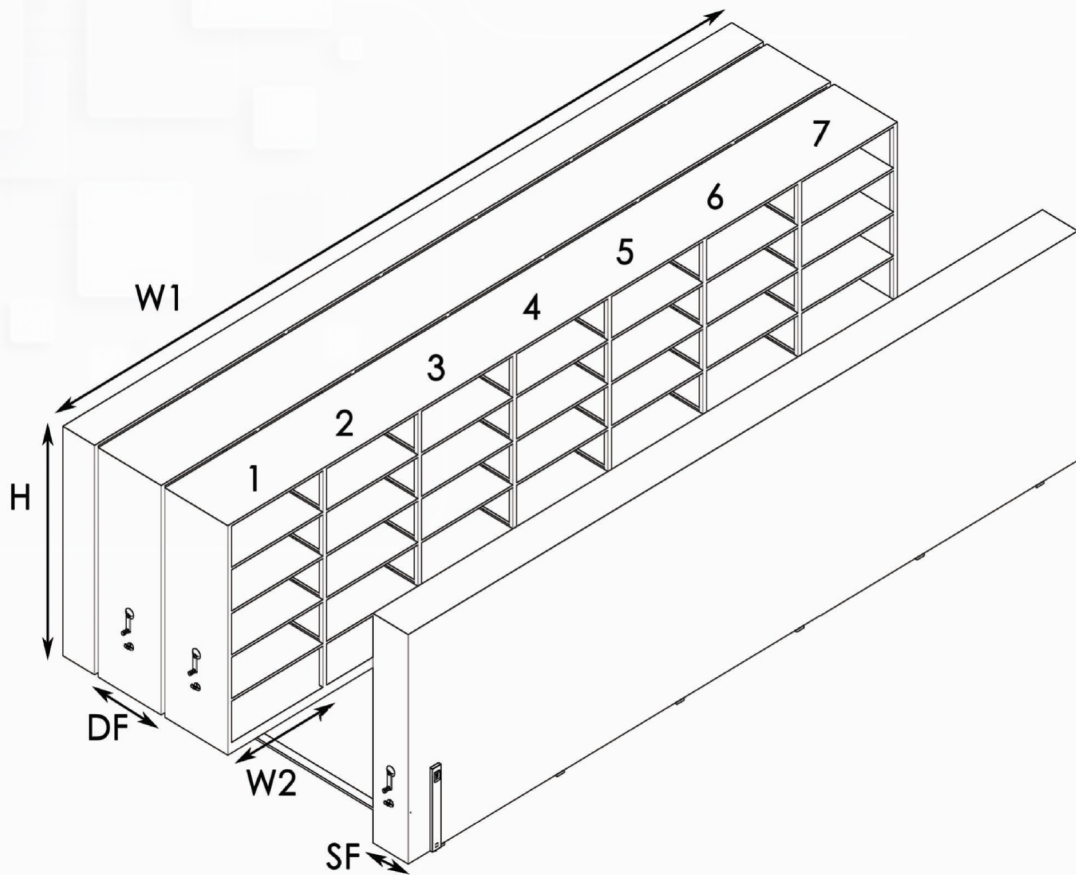

Unit Height, H - 2276, 2376, 2576, 2776, 2876, 3176, 3276, 3476
 Unit Width, W2 - 1300
 Number of Units - Upto 7
 Overall Width, W1 - 9300 (for 7 units)

(All dimensions in mm)

Depth of Shelves

Double Face, DF – 668, 868, 1068, 1268
 Single Face, SF – 336, 436, 536, 636

BRANCHES IN INDIA

EASTERN REGION : 033 66013801
 Kolkata : 033 66013802
 Guwahati : 0361 2468242

WESTERN REGION : 022 67961261
 Mumbai : 022 67961262 / 022 67961262
 Ahmedabad : 079 66060760
 Pune : 020 66255061

SOUTHERN REGION : 044 66544391
 Bengaluru : 080 66472009
 Chennai : 044 66544401
 Hyderabad : 040 66431294
 Coimbatore : 0422 2545588

NORTHERN REGION : 011 66507171
 Delhi : 011 66507178
 Chandigarh : 0172 5012727

BRANCHES OVERSEAS

UAE : 00 971 55899 2319
 Saudi Arabia : 00 966 50552 5744

GSS-MOBISTACKNEO-20-04-21



Godrej & Boyce Mfg. Co. Ltd

1, SIDCO Industrial Estate,
 Ambattur, Chennai 600 098, India
 Ph : 91 44 6654 4444
 Fax : 91 44 6654 4555 / 4445
 E-mail : storage@godrej.com
 www.godrejstoragesolutions.com